

INSTRUCTION MANUAL

1. DESCRIPTION

The Earth Leakage Relay *RD* is a microprocessor based electronic protection device designed to recognize low level leakage or unbalanced currents, due to insulation loss on conductors or equipment to be protected.

The fundamental feature of the *RD* is to allow preventive control of the system's insulation with continuous display of the earth leakage current value of motors, transformers and power systems. The measure of the leakage currents is obtained by the use of a ring-type current transformer. All circuit conductors to be protected shall go through the CT.

The *RD* product family includes:
RD-7 panel mounting relay 72x72
RD-9 panel mounting relay 96x96
RD-1 modular 35mm DIN rail

For more info go to the Technical Features paragraph and read the installation instructions.

The *RD* family relays present the following features:

- Direct digital display of the earth leakage current.
- Digital display of the fault current percentage value of the tripping.
- Independent current adjustments for alarm and tripping from 0.03 A to 10 A.
- Independent time adjustments for alarm and tripping, from 0.03 to 5 Secs.
- Control of two operational relays: alarm relay (Alarm) and tripping relay (Trip).
- One digital input for external reset (only RD-1 model).
- Indication and storage, in a non volatile memory, of the last trip's fault current.
- Manual test of output relays, displays and leds.
- Local or automatic programmable reset. The automatic reset is locked out after 3 trips within 9 minutes time.
- Continuous control of CT wiring connection.

Thanks to the digital HMI, it is possible to easily and precisely set the time and current values.

The *RD* relay, thanks to its internal filtering, is immune to external disturbances. Its function is also guaranteed with alternate sinusoidal and continually pulsating differential currents, abruptly or applied which rise slowly (type A).

2. INSTALLATION

The *RD* should be installed according the characteristics of humidity and temperature that has been designed to work in. To minimize noise pickup and interference the relay should be placed away from high current conductors or sources of strong magnetic fields.

The circuit conductors shall be placed in the center of the ring type current transformer (as showed in the figure).

Should the cables have a wide section and should they carry high levels of current, avoid to place the single conductors far from the center of the ring. In this case it will be necessary that the diameter of the Current Transformer shall be wider than the minimum necessary diameter.

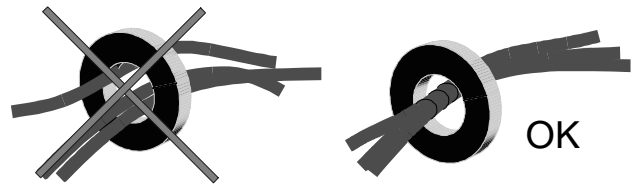

The *RD-1* is design to be installed over a din rail of 35mm (go to last page), while the *RD-7* and the *RD-9* have been studied for panel mounting.

3. ELECTRICAL WIRING CONNECTIONS

Follow the diagram on the last page.

Attention: Do not work on active circuits!

3.1 Power Supply

Terminals 1 and 2: for 115 Vac 50/60Hz and all DC models
Terminals 1 and 3: for 230 Vac 50/60Hz

note: *RD* does not have internal fuses.

important: Before doing the dielectric strength test of panel board, where the *RD* relay is installed, it is necessary to disconnect it from the power line voltage.

3.2 CT connection

The terminal blocks 10 and 11 should be connected to the measuring windings of the CT by twisted shielded cable. The used wire should not be less than 1 mm² and the distance should be as short as possible (max. 10 mt. of pair wire).

NOTE: The CT wiring should be placed away from high current conductors or sources of strong magnetic fields, to minimize noise pickup and interference on the *RD* relay. If the wires have only one route, separate the wires with some metallic element. Connect shield only to system ground.

3.3 Output contacts connections

The outputs consist of two mechanical relays with one changeover contact. The **TRIP** relay will activate when the earth leakage current overcome the trip threshold for the specified delay time or in case of problem with CT connection (see programming).

The **ALARM** relay will activate instantaneously when the *RD* is connected to line power, and it will be deactivated when:

- The earth leakage current overcome the alarm threshold for the specified delay time
- The auxiliary voltage is cut off.
- Problem with the CT connection (see programming)

NOTE: Using the contacts for control of inductive loads in Vac (coils of relays, contactors, solenoids), is necessary to limit the over current, or place a R/C group in parallel to the inductor. If it works in DC, a diode in anti-parallel should be connected. The internal relays are isolated 5 kV between contact and coil.

3.4 External reset wiring (only RD-1 model)

Connect terminals 12 & 13 to a dry contact (see wiring diagram RD-1). In case of presence of electromagnetic disturbances, use shielded cable.

4. FUNCTIONS AND SIGNALIZATIONS.

Each time the RD relay is powered, an internal check-up is made inside of the relay. The protection function will be available within 300ms and the DISPLAY will start displaying the current levels in Ampere (normal functioning condition) after 5s.

Note: In the case there is a wire interruption in the connection, the message "E01" will appear on the display.

DISPLAY:In the (3) digit display, the user can observe all the data of the RD: current levels, settings values and error codes.

"ALARM" LED :The "ALARM" led turned on shows that the current has risen above the alarm setpoint and the programmed alarm time. The respective contact has activated the alarm.

"TRIP" LED : The "TRIP" led turned on shows that the current has risen above the trip setpoint and the programmed trip time. The respective contact has activated the trip.

4.1 Set Menu

From the normal functioning mode (display of the current in Ampere), press the "▼" button to enter the menu for functions from L01 to L09. This allows to verify or modify the settings.

Each time the above mentioned button is pressed, it is possible to go the next function. The RD will continue to alternate the visualization of the function Lxx and the corresponding value.

To go back to the normal condition just press the button "Reset/Test".

To go back to the previous function press the "▲" button. The following points will explain in detail the complete menu:

L01 Last trip: Displays the current value of the last trip. The value is stored in a non-volatile memory.

L02 Trip Level: Displays the Ampere current value that corresponds to the trip threshold.

L03 Trip Time: Displays the delay time (in seconds) related to the Trip.

L04 Alarm Level: Displays the Ampere current value that corresponds to the Alarm threshold.

L05 Alarm Time: Displays the delay time (in seconds) related to the Alarm.

L06 Auto Reset: Displays if the automatic reset is ON or OFF in case of Trip.

L07 Test mode: Allows to visualize if the test functions of the Alarm and Trip relays is ON or OFF. If OFF, the TEST button will allow to test only the display and the leds.

L08 CT error mode: Displays which output relay will be active in case of connection problems with the toroidal transformer (ALr = Alarm, TrP = Trip, ALL = both, OFF= no relay).

L09 Trip mode: Displays in which mode will be operating the Trip relay (LA = Latched ; P0.1 impulsive with length of impulse 0,1 second; P0.2 impulsive 0,2s; P0.3 impulsive 0,3s; P0.4 impulsive 0,4s; P0.5 impulsive 0,5s; P0.6 impulsive 0,6s; P0.7 impulsive 0,7s; P0.8 impulsive 0,8s; P0.9 impulsive 0,9s)

From Menu mode, the user will be able to go back to the normal functioning condition by pressing the Reset button.

The display of the menu is interrupted after 30 seconds since the last time a button has been pressed. It will then automatically go back to the normal functioning condition.

For an immediate use of the menu, see Fig. 4 that explains how to move in the Menu mode and all the functions related to the buttons.

4.2 Display Mode: "Ampere" or "% Trip"

In the normal functioning mode, the RD will display the Ampere earth leakage. The minimum readable current is 0.02A.

Holding the "▲" button, the RD will display the actual earth leakage as percentage of the tripping. This visualization mode will be active as long as the "▲" button is held; in this mode for

current < 20mA the display will show "00P" and for current > Trip threshold the display will show "--P".

4.3 Error Codes

The device has been designed to control from time to time the internal hardware and the connection to the current transformer. In case of problems the relay is able to recognize the errors, displaying the following error codes:

E01 = CT Error : The current transformer is not connected to the earth leakage relay or there isn't a good connection between the two.

4.4 TEST function

The RD allows to verify the display and the correct functioning of the output relays. .

In order to run the test, it is necessary that the relay is in the normal functioning mode. Press the Reset button if you are in menu mode. If the relay has tripped and at least one led is active, reset the device pressing the Reset button. It's now possible to press the Test button, holding it to verify that all the segments of the display and the leds turn on. Releasing the Test button, the relay will go back to its normal functioning condition.

The RD will commute the Alarm and Trip relays only if ON is selected from L07 (Test Mode) and if the Test button is held for more than 5 secs. In order to inhibit the test of the relays, just select OFF from L07 of the menu.

4.5 Automatic Reset function

At line L06 of menu, it is possible to turn on (select ON) or off (select OFF) the RD's automatic reset function. In case this function is active and should the relay trip (the automatic reset doesn't involve the Alarm trip), the RD will wait for the leakage condition to self extinguish (the value of the measured current shall be lower than the Trip level) and after 2 secs, it will automatically run a reset. Should there be another trip of the relay, the RD will behave in the same way and it will therefore automatically reset. The RD will inhibit the auto-reset function should there be more than 3 trippings in 9 minutes time. In this case the user shall press the Reset button.

If the automatic reset function is turned off and in case of trip of the relay, press the Reset button or use the digital input (only RD-1 model) to reset the device.

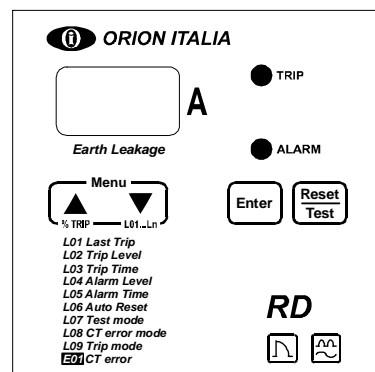
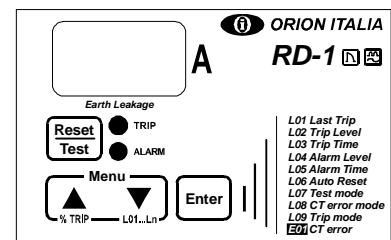

Fig. 1
RD-7 and RD-9

Fig. 2
RD-1



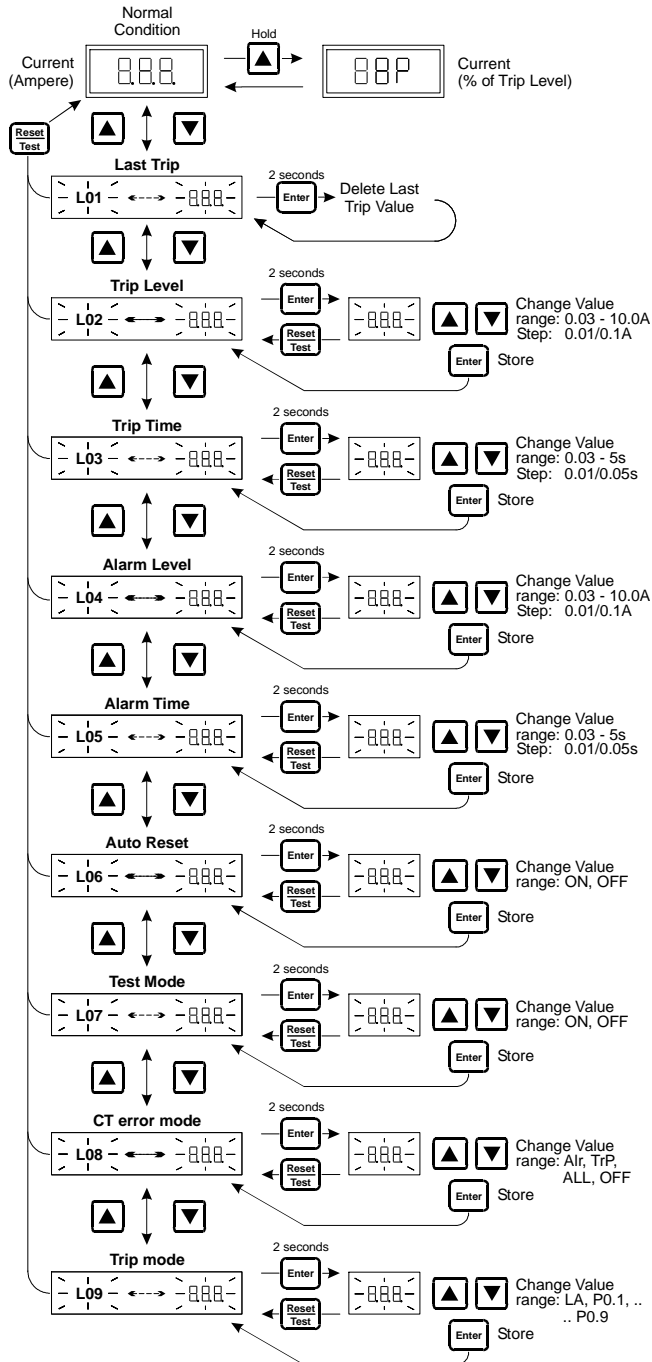

Fig.3

5. PROGRAMMING

With reference to Fig.4, in order to modify any setting, just reach the line of interest and hold the Enter button for more than 2 secs. Immediately, the value that must be modified will start blinking and the user will be able to modify it pressing the “▼” and “▲” buttons. Then, press Enter to store the value or Reset to delete the whole operation.

When the relay is displaying a blinking value (and this means that it is possible to modify the value) and after 30 sec since the last time a button has been pressed, it will automatically go back to the normal functioning condition.

6. TECHNICAL SPECIFICATIONS.

Supply voltage: 115/230 Vac -15%, +10% 50/60 Hz
110 Vdc -15%, +10% for RD-9E1
12Vdc; 24Vdc; 48Vdc -15%, +10% for DC models

Max. Power Consumption: 3VA or 3W

CT (Current Transformer) ratio: 1/500

Trip & Alarm current adjustment:

30 mA ÷ 10,0 A. Accuracy: ±5% ±1 digit

Trip & Alarm time adjustment:

30 ms ÷ 5 sec, steps 10 msec.

Accuracy 5% or ±10ms

Third Harmonic Filter:

Attenuation.83% @150 Hz

Attenuation.93% @180 Hz

CT wiring Test: Continuous.

Outputs: 2 outputs changeover with 8A 250 Vac resistive load.

Input: 1 logic input for dry contact.(RD-1 only).

Operational Temperature: From 0 ÷ 50°C

Storage Temperature: From -20 ÷ 70 °C

Relative Humidity: ≤ 90%

Burn In Test: 48 ore @ 50°C.

Reference Standards: In accordance to VDE, UL, CEI.

Terminal Block: Fixed connection terminals with a capacity of 5A, 250 Vac with cable section 2,5 mm² (14 AWG)..

RD-1:

Frame: NORYL UL 94 V-0 self-extinguish with protection (IP40)

Installation: Omega rail bar 35mm.

Dimensions: 71x90x58 mm.

Weight: 254 grammi.

RD-7, RD-9:

Frame: ABS UL 94 V-0 self-extinguish with polyester frontal sticker and protection (IP54).

Installation: Panel mounting

Dimensions: 72x72x100mm (RD-7); 96x96x100mm (RD-9).

Weight: 280 g (RD-7), 330g (RD-9).

Immunity tests

Reference standard: EN 50263

- Radiated emissions: EN 55022
- Conducted emissions: EN 55014
- Conducted disturbances induced by RF field.: EN 61000-4-6
- Radiated electromagnetic field.: EN 61000-4-3
- Electrostatic discharge: EN 60255-22-2
- Fast transients (burst): EN 60255-22-4
- Surge: EN 61000-4-5
- Voltage dips and short interruptions: EN 60255-11
- HF disturbances: EN 60255-22-1

Insulation tests:

Dielectric Test 2kV 50/60Hz for 1 min, reference EN 60255-5
Pulse Test 5kV (d.m.) 2kV (c.m.), reference EN 60255-5

How to order:

RDxx1 → standard model

→ A = 115/230Vac; G = 12Vdc; B = 24Vdc;

C = 48Vdc; E = 110Vdc (RD-9 only)

→ 1 = RD-1; 7 = RD-7; 9 = RD-9

7. MAINTENANCE

The RD relay required easy and few maintenance operations: Keep the device dry and clean.

Verify that the terminal blocks are well connected.

Periodically control the proper function of the leds, display and output contacts (see TEST function).

8. WARRANTY

The RD benefits of a 12 month warranty period, active from the date of shipment (stated in the delivery note) and valid for defects in material and workmanship.

This warranty does not apply to defects resulting from product modification without Orion Italia's express written consent, or misuse of any product or part. This warranty also does not apply to incorrect connection of probes, incorrect line power, supply voltage greater 10% Vn. In these cases, Orion Italia will not be responsible for damages caused by defective or damaged devices.

Costs to be considered at the customer's charge:

- All transport costs related to the defective returned devices, that have to be repaired or inspected.
- Travel and accommodation costs for the technician that has to provide on site assistance.

These costs are defined by the ANIMA, Col.C organization. Any conflict arising will be submitted for arbitration, in conformity with the arbitration rules of Piacenza Court.

ORION ITALIA reserves the right to modify the protection relay and/or replace the contents of the present manual without advising.

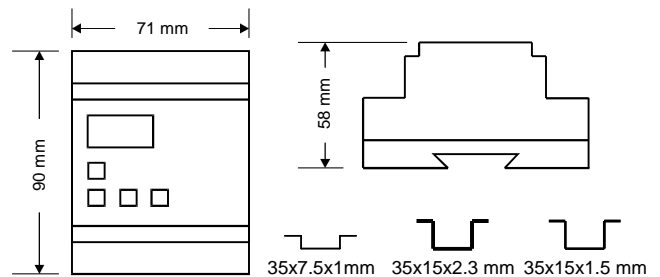
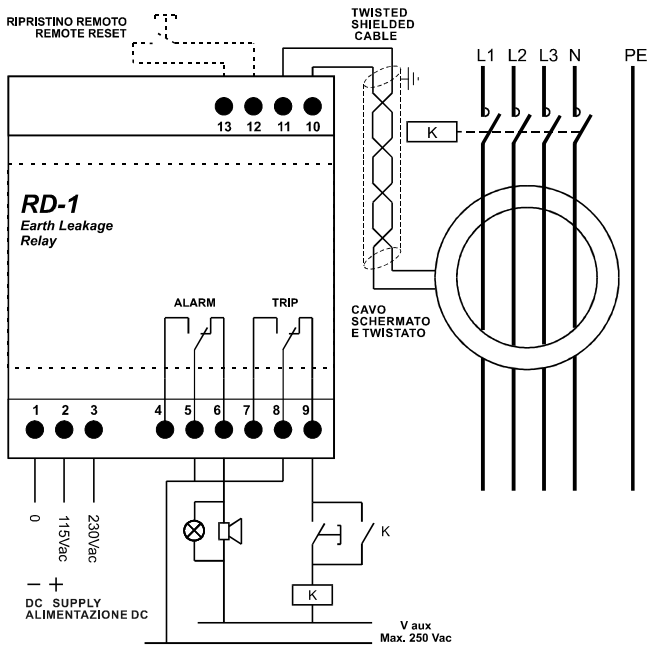

Fig. (a): RD-1 wiring diagram and dimensions (example using contactor)

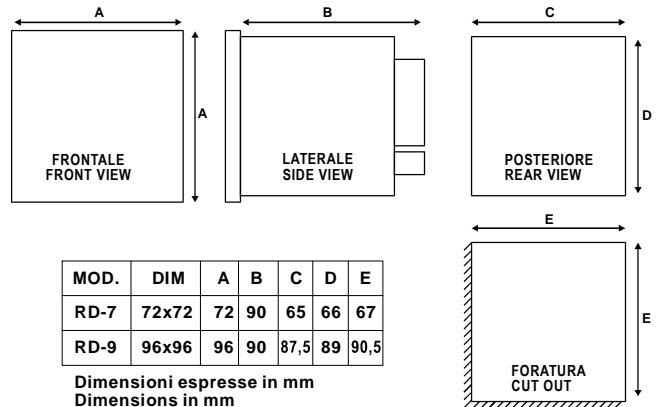
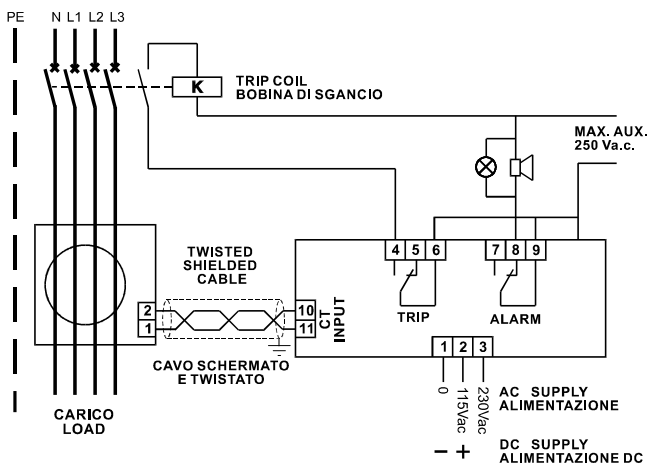

Fig. (b): RD-7 and RD-9 wiring diagram and dimensions (example using breaker)



Via G. Orsi 35, 29100 Piacenza [PC] – Italia
Telefono: ++ 39 0523 591161, Fax: ++ 39 0523 593898, Internet: www.orionitalia.com